

EDDYFI SURFACE PROBES



WE ARE EDDYFI TECHNOLOGIES.

Non-destructive testing (NDT) of critical components is a vital part of integrity management and safety in such industries as nuclear, power generation, oil and gas, and aerospace.

World-class engineering, nimble manufacturing, and some of the best minds in advanced eddy current testing allow Eddyfi Technologies to offer you the best performing, most reliable advanced electromagnetic hardware and software essential to you and your business.

With this standard line of surface probes, we are demonstrating a genuine commitment to the NDT industry. It offers:

Truly universal ECA solutions—Migrating from magnetic-particle (MT), penetrant (PT), and pencil-probe eddy current testing (ECT) is finally made simple. Gone are the headaches from choosing eddy current array (ECA) probes. Our probes are engineered to be easy to select and used straight out of the box... at competitive prices.

Performance—Our surface probes are designed with the highest standards, the best modeling software, the most advanced materials, and cutting-edge proprietary techniques. We use the most advanced topologies, surface-specific mechanical casings, real coils—no PCB-based alternative—which deliver the best possible signal quality and response to target defects.

Durability—All our surface ECA probes are designed for harsh environments; rugged and engineered to take on the real world.

Expertise and support—Our standard surface probes are backed by the best support in the industry. We have prime know-how and knowledge of ECA technology to help you use your probes so that they truly work for you.

Eddyfi Technologies is headquartered in beautiful Québec, Canada, at the heart of the city's advanced NDT cluster. We are the most dynamic company in the field of advanced NDT equipment—we've made it one of our missions to push the limits of electromagnetic testing to new heights, which we achieve by designing new generations of standards and specialized probes. This is how we manage to offer complete, high-end solutions for the inspection of critical components.

If, for some reason, our standard probes do not fit your specific needs, Eddyfi Technologies has all the necessary capabilities to develop custom solutions to tackle the most challenging applications.

For more information, visit www.eddyfi.com or contact us at probes@eddyfi.com.

DEMYSTIFYING THE TECHNOLOGY

Eddy current technologies take advantage of electromagnetic induction, where an alternating current flowing through a wire coil—generally copper—generates an oscillating magnetic field. When this magnetic field nears another electrically conductive material, a circular flow of electrons appears in the material, which is known as an eddy current. An eddy current also generates a magnetic field that interacts with the coil and its own magnetic field. Defects such as cracks in the electrically conductive material disrupt the flow of eddy current and its magnetic field, modifying the electrical impedance of the coil, making it possible to identify and characterize the defects.

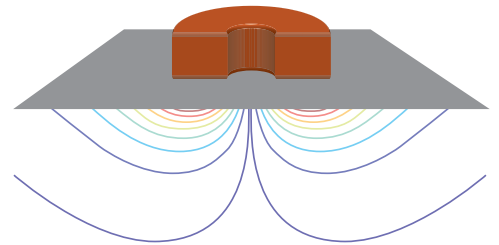

EDDY CURRENT TESTING

Usually referred to as ECT, it is the best non-ferrous component (e.g., stainless steel weld) inspection method. ECT makes it possible to reliably detect corrosion and surface cracking, for example. Such defects cause variations in the phase and magnitude of eddy currents generated by a transmitter coil, which are monitored by a receiver coil or by measuring the variations in the current flowing through the transmitter. This is the core of standard, single-element ECT.



EDDY CURRENT ARRAY

ECA technology uses many individual coils, grouped in one probe. The coils are excited sequentially to eliminate interference from mutual inductance (i.e., channel multiplexing). To optimize performance, ECA probes can be flexible or shaped to match specific geometries for simpler, one-pass inspections. Furthermore, probe data can be encoded. It is transmitted directly to software for graphical display (C-scan), record keeping, and reporting.

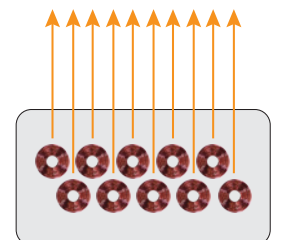

Because of the shorter inspection times, better detection, and complete inspection records, ECA probes can replace a number of traditional NDT inspection methods like MT, PT, and single-element ECT (above).

CHANNEL MULTIPLEXING

Channel multiplexing in ECA probes is achieved when groups of coils are excited at timed intervals to eliminate interference from mutual inductance, allowing them to work together in scanning wider inspection areas than conventional ECT probes. Coils are considered multiplexed when the active time interval of one or a combination of coils expires and the active time interval of other coils starts. Channel multiplexing has several advantages:

- Minimizes crosstalk between adjacent coils
- Increases the channel resolution and coil sensitivity
- Improves the signal-to-noise ratio of the probe

Channel multiplexing is achieved with the help of a device that connects and acquires signals from several groups of coils through a single instrument input. This device is intuitively called a multiplexer (MUX) and essentially works like a high-speed switch that successively connects each signal to the test instrument. Eddyfi-line Ectane® and Reddy® test instruments are equipped with SmartMUX™—an integrated, universal, programmable MUX—which takes care of channel multiplexing.

ECA TOPOLOGIES

Topologies refers to how coils are organized inside a probe and their activation patterns used in combination to create at least one eddy current channel. We offer a variety of advanced

topologies—some of the most commonly used in ECA probes are presented here. Other topologies can be used in custom probes. See page 26 for details.

IMPEDANCE

This topology can detect discontinuities oriented in any direction, especially where there is very little liftoff variation. The impedance topology can be separated into two modes:

Absolute—One coil is excited to generate eddy currents and to sense variations in their field.

Differential—Two coils are excited to generate eddy currents. When the two coils are over an area free from defects, there is

no differential signal between the coils, as they are both inspecting identical material. One coil over a defect while the other is over good material generates a differential signal, making it possible to characterize the defect.

All our impedance probes support both operating modes.

TRANSMIT—RECEIVE

The transmit-receive topology is generally comprised of two rows of coils and is directional, creating axial and/or transverse channels. Axial (or longitudinal) channels detect defects perpendicular to the array of coils, while transverse (or circumferential) channels detect those parallel to it.

Long, single driver—This topology uses a relatively conventional method of generating eddy current signals: a single coil is the transmitter (T). This single-driver topology is the best to detect large and/or subsurface defects, and offers a better tolerance to liftoff than the double-driver topology.

Short, double driver—This topology uses two coils, excited simultaneously, acting as one large transmitter. The large area (ergo higher resolution) offers—over the single-driver topology—a better response and sensitivity to small defects. It has, however, fewer channels than the single-driver topology for the same number of coils.

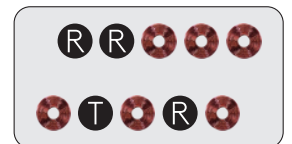

Long, single driver

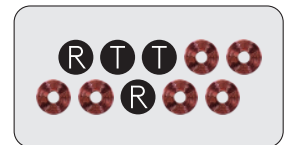

Short, double driver

TANGENTIAL ECA (TECA™)

This topology incorporates tangential coils that yield a very specific eddy current signal for surface-breaking cracks in carbon steel. As illustrated, the liftoff signal is almost horizontal and crack-like indications are approximately 90° relative to it.

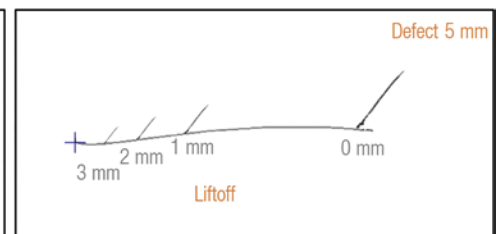
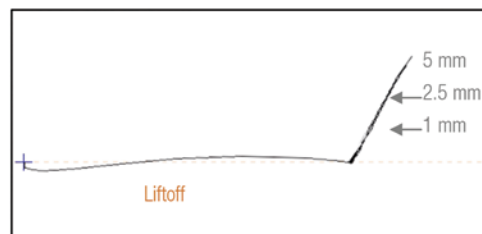

THE RIGHT SURFACE PROBE FOR THE JOB

CUSTOM BODY AND RIGID PROBES

Rugged and tailored to your needs, they minimize liftoff for high, uniform sensitivity, making them the probes of choice for flat surfaces. They are easy to handle and their designs make them extremely reliable. They offer many frequency brackets, number of coils, and (in the case of rigid probes) casing sizes (small, medium, and large). Inquire about availability.

SEMI-FLEXIBLE PROBES

These easily bend to perform axial scans on convex or concave geometries with height variations along a single axis (such as pipes and floor plates). They offer several frequency brackets, number of coils, and casing sizes (small, medium, and large).

PADDED PROBES

Going one step further, padded probes can adapt to all geometry variations, in every direction, which makes them perfect for weld beads, transitions, and heat-affected zones. The unique, proprietary design makes it possible to detect surface cracks in welds with little surface preparation. The probe's membrane is extra-tough to better withstand friction. Like other Eddyfi surface probes, padded probes offer many frequency brackets, number of coils, and casing sizes (small and medium).

FLEXIBLE PROBES

These probes are specifically designed to fit complex geometries, which makes them perfect for one-pass examinations of pipes, nozzles, turbine blades, wheels, and any other smooth, curved surface. They can be used in a wide range of applications that were previously challenging for ECA technology. I-Flex™ probes are available in three sizes—small, medium, large—and their unique design offers three built-in topologies, making them the perfect tool for challenging applications and trials. T-Flex™ probes are available in medium size only.

SHARCK™ PROBES

Sharck probes combine the benefits of rigid and semi-flexible probes. Their spring-loaded fingers adapt to the geometry of weld crowns, making it possible to quickly scan the weld cap, the toe area, and the heat affected zone in a single pass. This design is mostly used in combination with the patent-pending TECA™ technology to inspect carbon steel welds.

PROBE NUMBERING

Probe numbers are located on the probe's Fischer connector.

TYPE

- ECA
- SHARCK
- GEAR

BODY TYPE

- RB: rigid
- SF: semi-flexible
- PD: padded
- TF: T-Flex
- IF: I-Flex

TOPOLOGY TYPE

- A: impedance
- C: long, single driver
- D: short, double driver
- G: multitopology

APPLICATION TYPE

- BW: butt weld
- FW: fillet weld
- HR: high resolution

COMPATIBLE INSTRUMENT

- E: Ectane
- R: Reddy

COVERAGE

This is the width covered by the probe's active surface, in millimetres.

CENTRAL FREQUENCY

- LXX: frequency in hertz, divided by 10 (e.g., 500 Hz=L50)
- XXX: frequency in kilohertz (e.g., 10 kHz=010)
- XXM: frequency in megahertz (e.g., 2 MHz=02M)

SHARCK - BW053 - G2 - E - N05S
Technology Weld type Coverage Generation Compatible instrument Cable type Cable exit position
length

GEAR - M20_30 - 076 - N03T
Technology Module range Coverage Cable type Cable exit position
length

ECA - SFD - 056 - 250 - 032 - N03S
Technology Body Topology Coverage Central frequency Coil number Cable type Cable exit position
length



MINIMUM CHANNEL REQUIREMENT	COVERAGE	CASING	PROBE NUMBER	PAGE	
64	53 mm (2.1 in)	Medium	SHARCK-BW053-G2-R-N05S or SHARCK-BW053-G2-E-N05S	page 8	
32	30 mm (1.2 in)	Medium	SHARCK-FW028-G2-R-N05S or SHARCK-FW028-G2-E-N05S	page 8	
32	7 mm (0.3 in)	Straight pencil	SHARCK-PEN-ST-N05TE or SHARCK-PEN-ST-N05TR	page 9	
32	7 mm (0.3 in)	Right-angle pencil	SHARCK-PEN-RA-N05TE or SHARCK-PEN-RA-N05TR	page 9	
64	71 mm (2.8 in)	Semi-flexible and conformable	SHARCK-HR-1048-071-N05SE or SHARCK-HR-1048-071-N05SR	page 10	
32	128 mm (5.0 in)	Extra-large	ECA-IFC-128-005-033-N03SA	page 11	
32 or 64	79 mm (3.1 in)	Large	ECA-IFG-079-250-048-N03S	page 11	
32 or 64			ECA-IFG-079-050-048-N03S	page 12	
32 or 64	56 mm (2.2 in)	Medium	ECA-IFG-056-250-048-N03S	page 12	
32 or 64			ECA-IFG-056-050-048-N03S	page 13	
32 or 64	34 mm (1.3 in)	Small	ECA-IFG-034-500-048-N03S	page 13	
64	70 mm (2.8 in)	Medium	ECA-TFC-070-300-044-N03S	page 15	
64	70 mm (2.8 in)		ECA-TFC-070-045-044-N03S	page 15	
128	112 mm (4.4 in)	Large	GEAR-M30_42-112-N03T	page 16	
64	76 mm (3.0 in)	Medium	GEAR-M20_30-076-N03T	page 16	
32	50 mm (2.0 in)	Small	GEAR-M13_20-050-N03T	page 17	
32	128 mm (5.0 in)	Large Minimum OD 0.9 m (36 in)	ECA-SFC-128-005-033-N03S	page 18	
32	64 mm (2.5 in)	Medium Minimum OD 0.4 m (16 in)	ECA-SFC-064-005-017-N03S	page 18	
64	58 mm (2.3 in)		ECA-SFC-058-250-032-N03S	page 19	
64	56 mm (2.2 in)		ECA-SFD-056-250-032-N03S	page 19	
128	71 mm (2.8 in)		ECA-SFC-071-500-064-N03S	page 20	
128	70 mm (2.8 in)		ECA-SFD-070-500-064-N03S	page 20	
64	35 mm (1.4 in)		Small Minimum OD 0.2 m (8 in)	ECA-SFC-035-500-032-N03S	page 21
64	34 mm (1.3 in)	Medium	ECA-SFD-034-500-032-N03S	page 21	
64	58 mm (2.3 in)		ECA-PDC-058-250-032-N03S	page 22	
64	56 mm (2.2 in)		ECA-PDD-056-250-032-N03S	page 22	
128	55 mm (2.2 in)		ECA-PDC-055-500-050-N03S	page 23	
128	54 mm (2.1 in)		ECA-PDD-054-500-050-N03S	page 23	
64	35 mm (1.4 in)		Small	ECA-PDC-035-500-032-N03S	page 24
64	34 mm (1.3 in)			ECA-PDD-034-500-032-N03S	page 24

CARBON STEEL — SHARCK PROBES

The patented Sharck probe is specifically designed for cracking in carbon steel using tangential eddy current array (TECA) technology. These probes are capable of positioning cracks, measuring their length, and sizing them as deep as 7 mm (0.28 in). This can be achieved without removing paint or protective coatings, unlike more conventional techniques.

SHARCK-BW053-G2-R-N05S OR SHARCK-BW053-G2-E-N05S

Designed to scan the weld cap, toe area, and heat affected zone of a typical 12.7 mm (0.5 in) thick butt weld in a single pass.

Body	Butt weld Sharck
Topology	TECA
Casing	Medium
Coverage	53 mm (2.09 in)
Fingers	22 (11 × 2 rows)
Minimum channel requirement	64
Frequency	Tuned, fixed at 20 kHz and 80 kHz
Encoder (20.53 counts/mm)	E: Ectane R: Reddy
Cable	5 m (16.4 ft)
Maximum surface temperature	100 °C (212 °F)
Minimum pipe diameter for circumferential weld scan	25.4 cm (10 in)
Minimum pipe diameter for axial weld scan	40.6 cm (16 in)

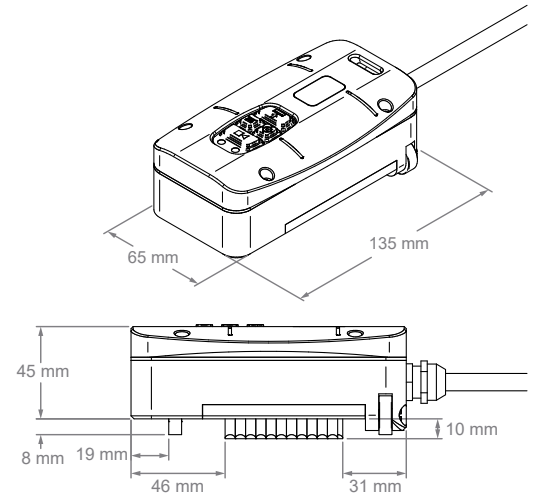

SHARCK-FW028-G2-R-N05S OR SHARCK-FW028-G2-E-N05S

Designed for carbon steel fillet weld crack detection and depth sizing.

Body	Fillet weld Sharck
Topology	TECA
Casing	Medium
Coverage	28 mm (1.10 in)
Fingers	12 (6 on cap, 6 on HAZ)
Minimum channel requirement	32
Frequency	Tuned, fixed at 20 kHz and 80 kHz
Cable	5 m (16.4 ft)
Connector	E: Ectane R: Reddy
Maximum surface temperature	100 °C (212 °F)
Fillet range	12.4–23.0 mm (0.50–0.91 in)
Minimum weld curvature radius	31.8 cm (15 in) concave and convex

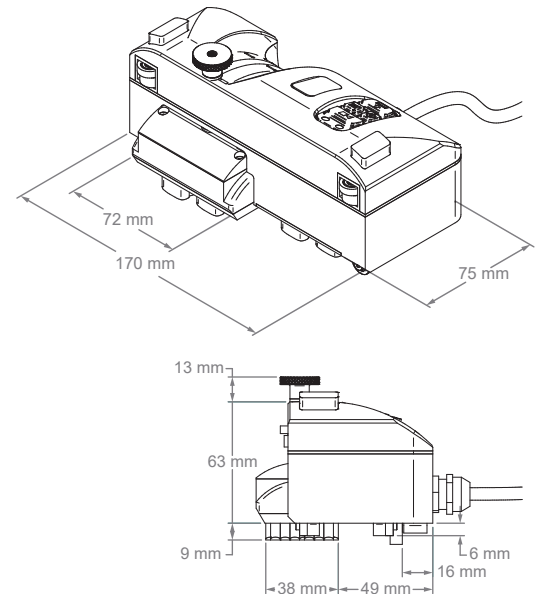

SHARCK-PEN-ST-N05TE OR SHARCK-PEN-ST-N05TR

Straight Sharck pencil probe.

Body	Pencil Sharck
Casing	Straight
Coverage	Approximately 7 mm (0.3 in) at -6 dB
Fingers	1
Minimum channel requirement	32
Frequency	Tuned, fixed at 20 kHz and 80 kHz
Cable	5 m (16.4 ft)
Connector	E: Ectane R: Reddy
Maximum surface temperature	100 °C (212 °F)

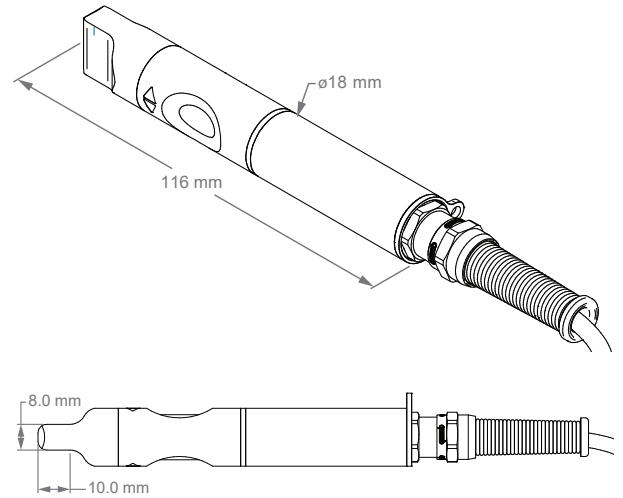

SHARCK-PEN-RA-N05TE OR SHARCK-PEN-RA-N05TR

90° Sharck pencil probe.

Body	Pencil Sharck
Casing	Right angle
Coverage	Approximately 7 mm (0.3 in) at -6 dB
Fingers	1
Minimum channel requirement	32
Frequency	Tuned, fixed at 20 kHz and 80 kHz
Cable	Standard, 5 m (16.4 ft)
Connector	E: Ectane R: Reddy
Maximum surface temperature	100 °C (212 °F)

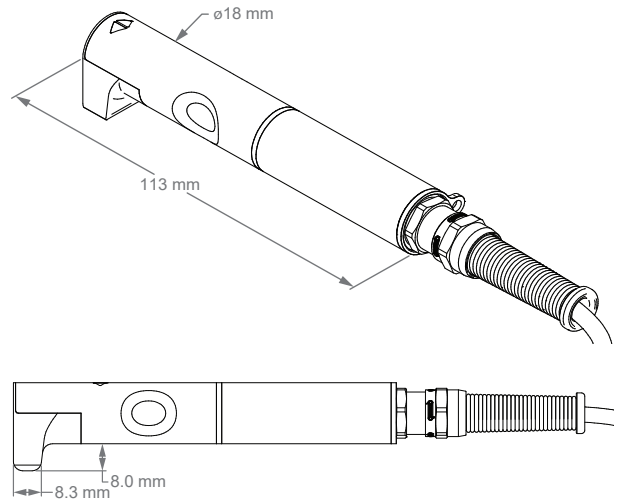

PERFORMANCE

ITEM	VALUE	NOTE
Detectable defect range (length × depth)	2 × 0.5 mm (0.08 × 0.02 in)	Results may vary according to crack location, liftoff, etc.
Maximum measurable crack depth	7 mm (0.28 in)	Typical, with good accuracy, but can detect deeper cracks
Sizing accuracy (length, depth)	±2 mm (0.08 in), ±10–20 %	Typical when using 0.5 mm (0.02 in) scan resolution and depending on weld conditions
Scan speed	Up to 200 mm/s (7.9 in/s)	With full data recording
Liftoff tolerance	Up to 3 mm (0.12 in)	Non-conductive coatings and paints, with monitoring and auto-correction

SHARCK-HR-1048-071-N05SE OR SHARCK-HR-1048-071-N05SR

The high-resolution Sharck probe, combined with a Reddy® portable instrument, is the fastest in-ditch pipeline integrity solution on the market. It enables measuring the depth of stress-corrosion cracking (SCC).

Body	High-resolution Sharck
Casing	Semi-flexible and conformable
Coverage	71 mm (2.8 in)
Minimum channel requirement	64
Frequency	Tuned, fixed at 100 kHz
Encoder (20.53 counts/mm)	E: Ectane R: Reddy
Cable	5 m (16.4 ft)
Compatible pipe diameters (NPS)	254–1220 mm (10–48 in)

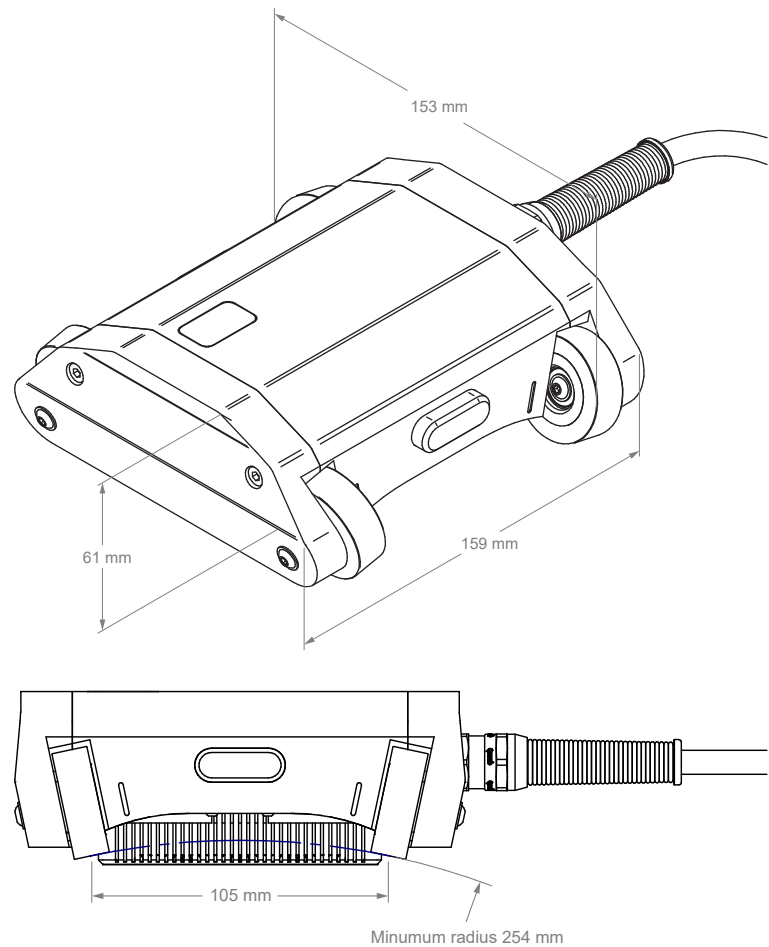

PERFORMANCE

ITEM	VALUE	NOTE
Detectable defect range (length × depth)	2 × 0.25 mm (0.08 × 0.01 in)	Results may vary according to crack location, liftoff, etc.
Maximum measurable crack depth	Typically 3 mm (0.120 in) with good accuracy	Can detect deeper cracks—system yields 3 mm+ (0.118 in+) results
Depth sizing accuracy	±10 %	The presence of corrosion may affect accuracy
Scan speed	Up to 600 mm/s (24 in/s)	With full data recording
Liftoff tolerance	Up to 2 mm (0.08 in)	Non-conductive coatings and paints, with monitoring and auto-correction
Materials	X52 grade steel	X56, X60, and more grades to be supported

COMPLEX GEOMETRIES — FLEXIBLE PROBES

I-FLEX PROBES

The all-round best flexible, plug-and-play probes in the industry. I-Flex are also engineered using actual coils, yielding high-quality signals and better detection capabilities. I-Flex are designed for surfaces with a bend radius of 20 mm (0.787 in) or more.

ECA-IFC-128-005-033-N03SA

The extra-large I-Flex is specifically designed to detect far-surface corrosion and subsurface indications in non-ferromagnetic materials. The probe offers the largest possible coverage in corrosion-mapping applications.

Body	I-Flex
Casing	Extra-large
Topologies	Long, single driver
Cable	3 m (9.8 ft)
Coverage	128 mm (5.04 in)
Central frequency	5 kHz
Frequency range	0.6–20 kHz
Coils (diameter × number)	6 mm × 33 (0.24 in × 33)
Channels (according to topology)	32
Minimum channel requirement	32
Penetration (stainless steel/aluminum)	Up to 6 mm (0.236 in)

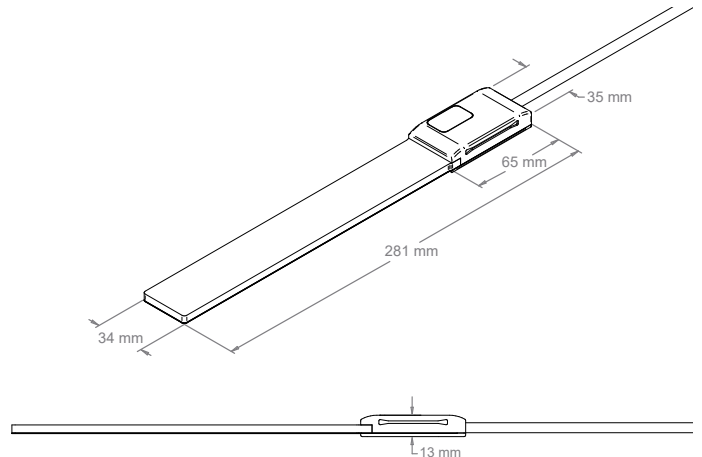

ECA-IFG-079-250-048-N03S

The large I-Flex is excellent for detecting subsurface indications and surface-breaking indications. The three, built-in, adaptorless topologies make the probe perfect for a broad range of challenging applications.

Body	I-Flex
Casing	Large
Topologies	Impedance Long, single driver Short, double driver
Cable	3 m (9.8 ft)
Coverage	79 mm (3.11 in)
Central frequency	250 kHz
Frequency range	50–525 kHz
Coils (diameter × number)	5 mm × 48 (0.20 in × 48)
Channels (according to topology)	32, 59, 60
Minimum channel requirement	32 or 64
Penetration (stainless steel/aluminum)	Up to 3 mm (0.118 in)
Minimum detectable crack length	1.5 mm (0.059 in)

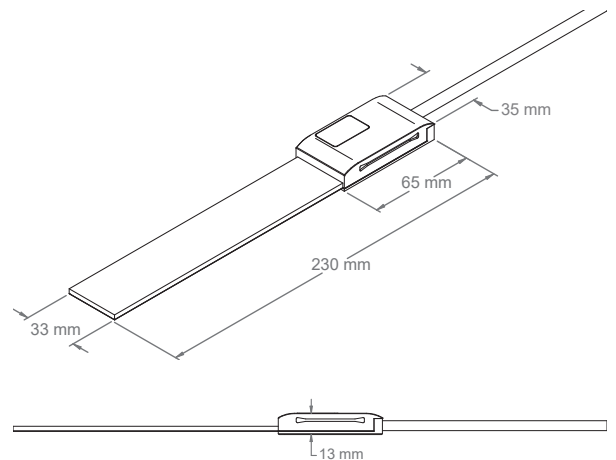

ECA-IFG-079-050-048-N03S

This large I-Flex benefits from its low frequency to reliably detect far-surface corrosion, subsurface indications, and surface-breaking indications. The three, built-in, adaptorless topologies make it perfect for a broad range of challenging applications.

Body	I-Flex
Casing	Large
Topologies	Impedance Long, single driver Short, double driver
Cable	3 m (9.8 ft)
Coverage	79 mm (3.11 in)
Central frequency	50 kHz
Frequency range	10–150 kHz
Coils (diameter × number)	5 mm × 48 (0.20 in × 48)
Channels (according to topology)	32, 59, 60
Minimum channel requirement	32 or 64
Penetration (stainless steel/aluminum)	Up to 4 mm (0.158 in)

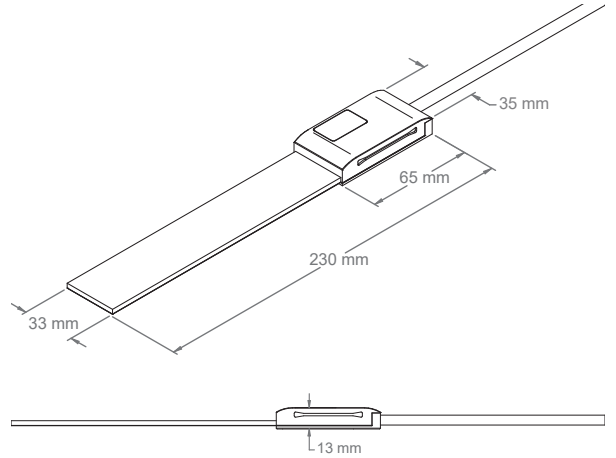

ECA-IFG-056-250-048-N03S

Excellent for detecting subsurface indications and surface-breaking indications. The three, built-in, adaptorless topologies make this probe perfect for a broad range of challenging applications.

Body	I-Flex
Casing	Medium
Topologies	Impedance Long, single driver Short, double driver
Cable	3 m (9.8 ft)
Coverage	56 mm (2.21 in)
Central frequency	250 kHz
Frequency range	50–525 kHz
Coils (diameter × number)	3.5 mm × 48 (0.14 in × 48)
Channels (according to topology)	32, 59, 60
Minimum channel requirement	32 or 64
Penetration (stainless steel/aluminum)	Up to 2 mm (0.079 in)
Minimum detectable crack length	1 mm (0.039 in)

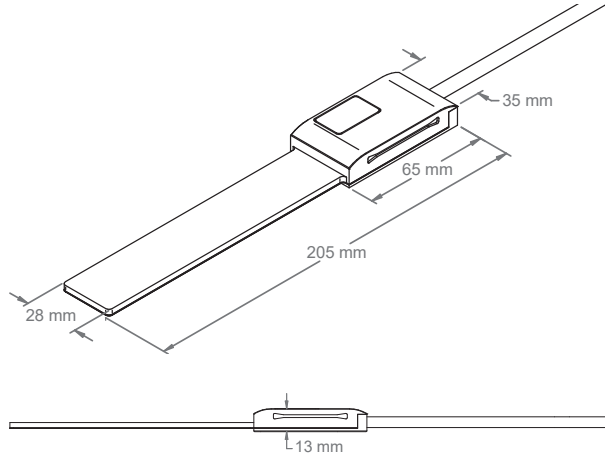

ECA-IFG-056-050-048-N03S

Excellent for detecting far-surface corrosion, subsurface indications, and surface-breaking indications. The three, built-in, adaptorless topologies make this probe perfect for a broad range of challenging applications.

Body	I-Flex
Casing	Medium
Topologies	Impedance Long, single driver Short, double driver
Cable	3 m (9.8 ft)
Coverage	56 mm (2.21 in)
Central frequency	50 kHz
Frequency range	10–150 kHz
Coils (diameter × number)	3.5 mm × 48 (0.14 in × 48)
Channels (according to topology)	32, 59, 60
Minimum channel requirement	32 or 64
Penetration (stainless steel/aluminum)	Up to 3 mm (0.118 in)

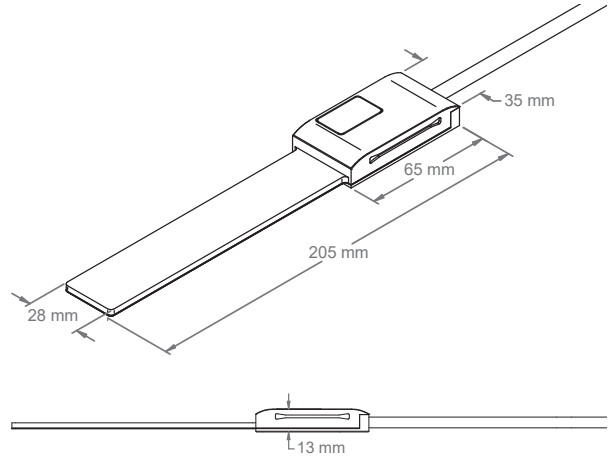

ECA-IFG-034-500-048-N03S

This super-high-resolution I-Flex is designed to detect very short, surface-breaking indications. The three, built-in, adaptorless topologies make this probe perfect for a broad range of challenging applications.

Body	I-Flex
Casing	Small
Topologies	Impedance Long, single driver Short, double driver
Cable	3 m (9.8 ft)
Coverage	34 mm (1.34 in)
Central frequency	500 kHz
Frequency range	100–800 kHz
Coils (diameter × number)	2 mm × 48 (0.08 in × 48)
Channels (according to topology)	32, 59, 60
Minimum channel requirement	32 or 64
Minimum detectable crack length	0.5 mm (0.020 in)

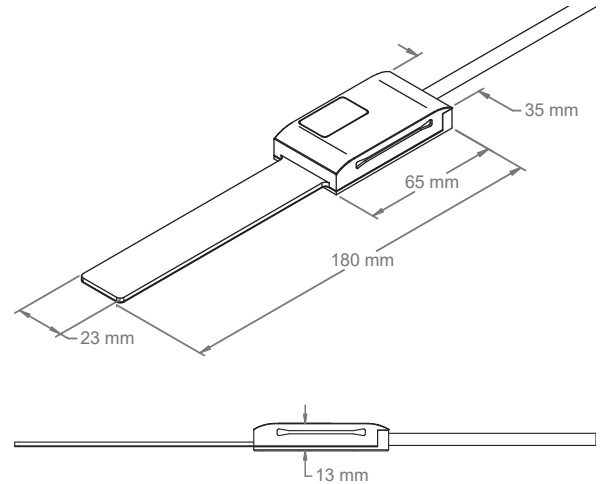

UNIVERSAL I-FLEX MANUAL PIPE SCANNER

ECA-AMPS-IF-042/170-N03R/ECA-AMPS-IF-042/170-N03E

Versatile scanner engineered to make it easier for operators to deploy Eddyfi I-Flex probes on tubes and pipes. It is the only scanner for I-Flex probes fitting tubes and pipes with outer diameters 42–170 mm (1.25–6.00 in NPS), depending on the probe model. Thanks to its low profile and light design, the scanner allows operators to replace several uncomfortable manual scans with one rapid axial scan, while maintaining a constant clock position. The scanner comes with an 18-pin connector (Ectane) or a 12-pin connector (Reddy), and a 3 m (9.8 ft) cable.

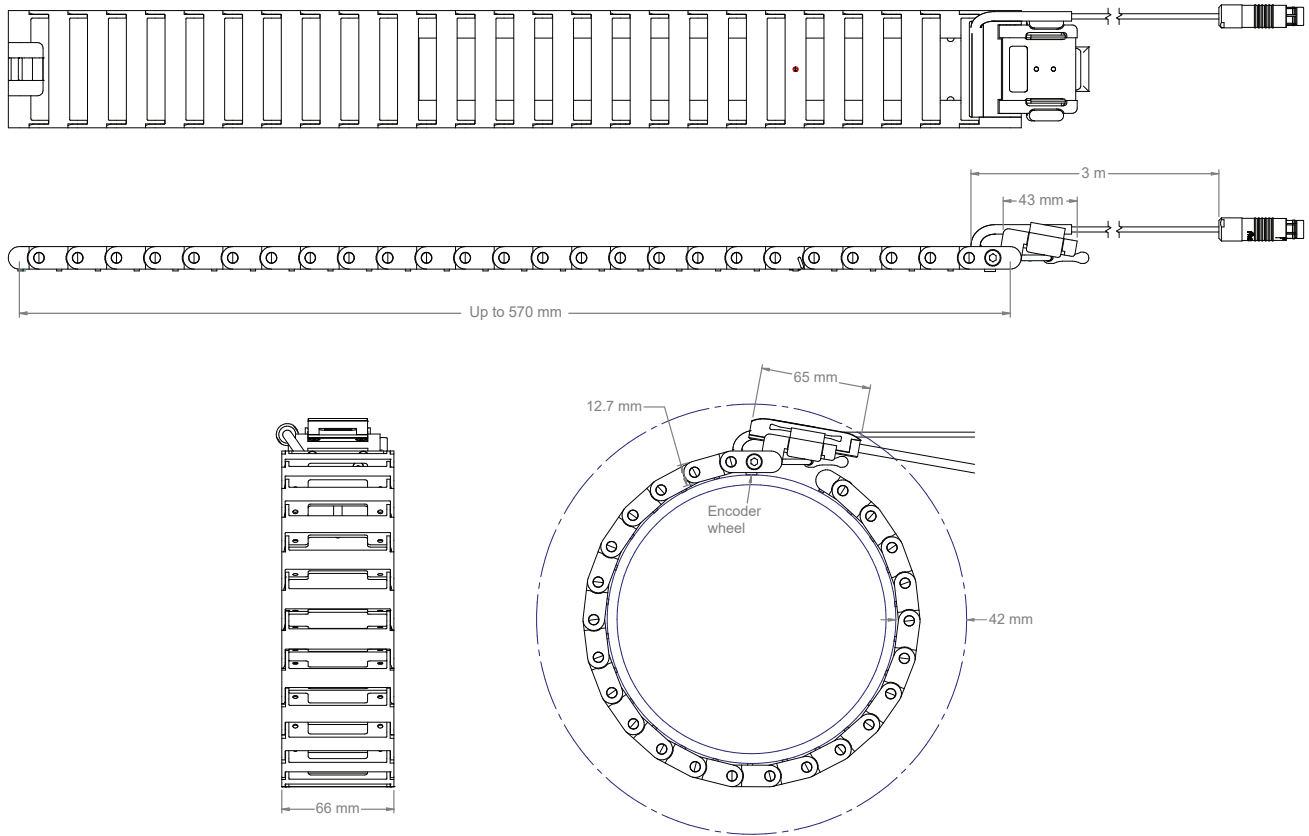

T-FLEX PROBES

Highly flexible, plug-and-play probes engineered with actual coils, yielding high-quality signals and better detection capabilities in a T configuration, which is better suited to some types of inspection. T-Flex probes are designed for surfaces with a bend radius of 20 mm (0.79 in) or more.

ECA-TFC-070-300-044-N03S

Designed to detect surface-breaking cracks and other surface defects on various smooth surfaces. Unleash the full potential of the probe by using transverse and axial channels (requires 128 channels), making it possible to detect defects in any orientations.

Body	T-Flex
Casing	Medium
Topology	Long, single driver
Cable	3 m (9.8 ft)
Coverage	70 mm (2.76 in)
Central frequency	300 kHz
Frequency range	100–600 kHz
Coils (diameter × number)	3 mm × 44 (0.12 in × 44)
Channels	63 (83 with all trans. ch.)
Minimum channel requirement	64
Minimum detectable crack length	1.5 mm (0.059 in)

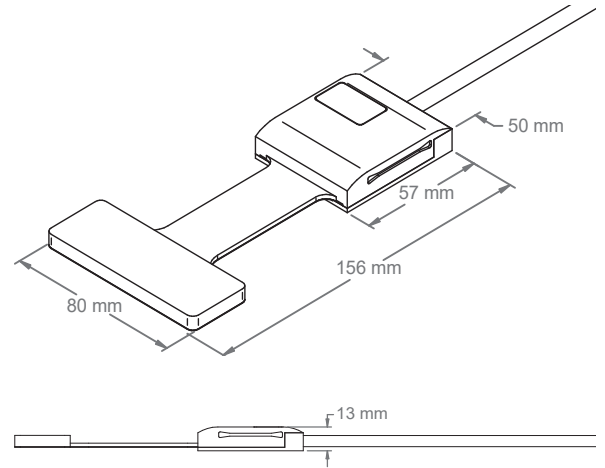

ECA-TFC-070-045-044-N03S

Low-frequency probe designed to detect some subsurface indications and surface-breaking cracks on various smooth surfaces. Unleash the full potential of the probe by using transverse and axial channels (requires 128 channels), making it possible to detect defects in any orientations.

Body	T-Flex
Casing	Medium
Topology	Long, single driver
Cable	3 m (9.8 ft)
Coverage	70 mm (2.76 in)
Central frequency	45 kHz
Frequency range	5–100 kHz
Coils (diameter × number)	3 mm × 44 (0.12 in × 44)
Channels	63 (83 with all trans. ch.)
Minimum channel requirement	64
Penetration (stainless steel/aluminum)	Up to 3 mm (0.118 in)
Minimum detectable crack length	1.5 mm (0.059 in)

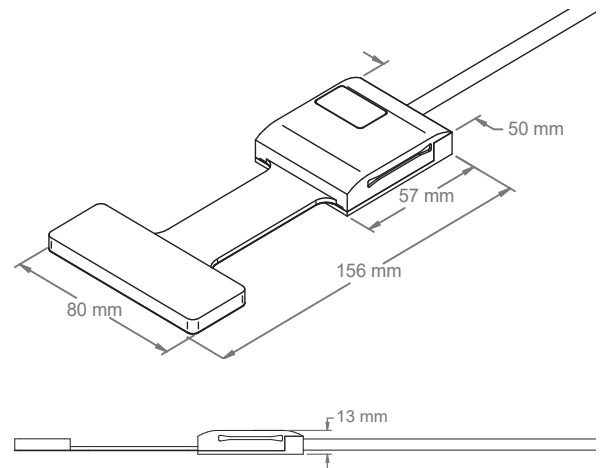

GEAR TEETH—GEAR PROBES

Over time, gear teeth are prone to surface cracking because of the constant torque they are submitted to. Surface-breaking cracks are typically found in the addendum, dedendum, and fillet of gear teeth, although they can also occur elsewhere.

GEAR-M30_42-112-N03T

Designed to inspect the cogs of large gears with a module ranging 30–42. The probe is engineered to detect short, surface-breaking cracks, and other surface defects in ferromagnetic materials with a high accuracy.

Body	Gear
Casing	Large
Topology	Long, single driver
Cable	3 m (9.8 ft)
Coverage	112 mm (4.4 in)
Central frequency	500 kHz
Frequency range	250 kHz–1 MHz
Coils (diameter × number)	4.5 mm × 48 (0.18 in × 48)
Channels	91
Minimum channel requirement	128
Minimum detectable crack length	5 mm (0.197 in)

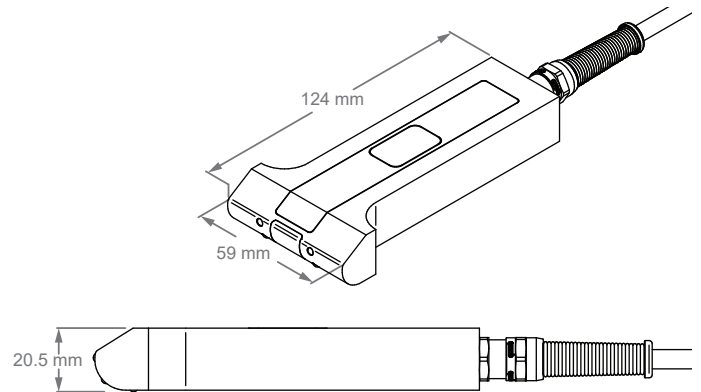

GEAR-M20_30-076-N03T

Designed to inspect the cogs of large gears with a module ranging 20–30. The probe is engineered to detect short, surface-breaking cracks, and other surface defects in ferromagnetic materials with a high accuracy.

Body	Gear
Casing	Medium
Topology	Long, single driver
Cable	3 m (9.8 ft)
Coverage	76 mm (3.0 in)
Central frequency	500 kHz
Frequency range	250 kHz–1 MHz
Coils (diameter × number)	4.5 mm × 33 (0.18 in × 33)
Channels	61
Minimum channel requirement	64
Minimum detectable crack length	5 mm (0.197 in)

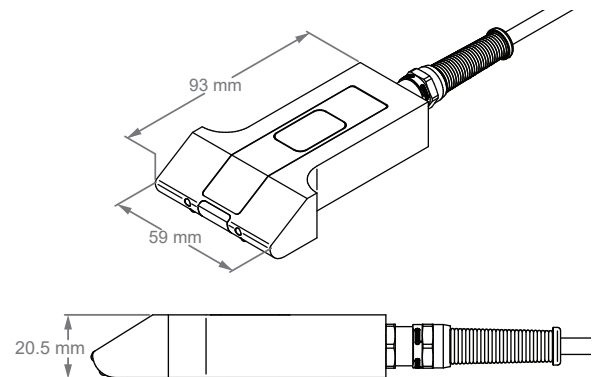

GEAR-M13_20-050-N03T

Designed to inspect the cogs of gears with a module ranging 13–20. The probe is engineered to detect short, surface-breaking cracks and other surface defects in ferromagnetic materials with a high accuracy.

Body	Gear
Casing	Small
Topology	Long, single driver
Cable	3 m (9.8 ft)
Coverage	50 mm (2.0 in)
Central frequency	500 kHz
Frequency range	250 kHz–1 MHz
Coils (diameter × number)	4.5 mm × 22 (0.18 in × 22)
Channels	48
Minimum channel requirement	32, 64
Minimum detectable crack length	5 mm (0.197 in)

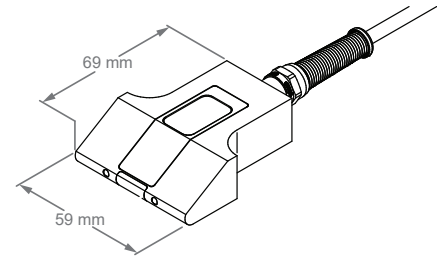

CURVED SURFACES — SEMI-FLEXIBLE PROBES

Designed for curved surfaces, such as pipes and pressure vessels. The sizes of casings determine the smallest diameter the probes can address, and is specific to each model.

Semi-flexible probes are also suited to flat surfaces.

ECA-SFC-128-005-033-N03S

Specifically designed to detect far-surface corrosion and subsurface cracks in non-ferromagnetic materials, this probe offers the largest possible coverage in corrosion-mapping applications. It can be used on curved surfaces with an outside diameter of 0.91 m (36 in) or more.

Body	Semi-flexible
Casing	Large
Topology	Single driver
Cable	3 m (9.8 ft)
Coverage	128 mm (5.04 in)
Central frequency	5 kHz
Frequency range	0.6–20 kHz
Coils	6 mm × 33 (0.24 in × 33)
Channels	32
Minimum channel requirement	32
Penetration (stainless steel/aluminum)	Up to 6 mm (0.236 in)

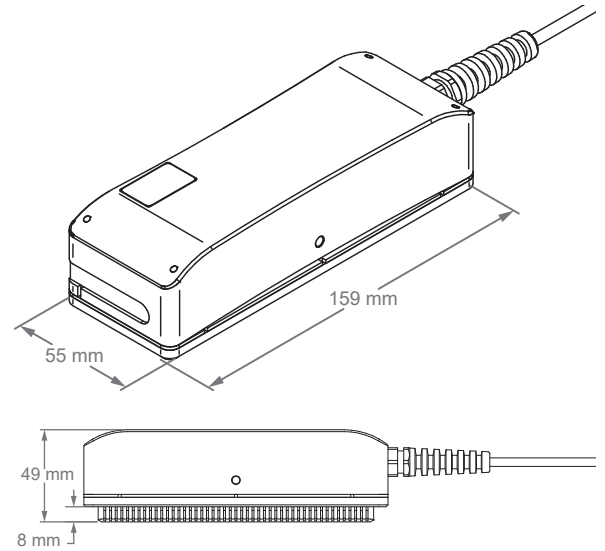

ECA-SFC-064-005-017-N03S

Specifically designed to detect far-surface corrosion and subsurface cracks in non-ferromagnetic materials, this probe offers half the coverage of ECA-SFC-128-005-033-N03S (above) in corrosion-mapping applications where access is limited. It can be used on curved surfaces with an outside diameter of 0.41 m (16 in) or more.

Body	Semi-flexible
Casing	Medium
Topology	Single driver
Cable	3 m (9.8 ft)
Coverage	64 mm (2.52 in)
Central frequency	5 kHz
Frequency range	0.6–20 kHz
Coils (diameter × number)	6 mm × 17 (0.24 in × 17)
Channels	16
Minimum channel requirement	32
Penetration (stainless steel/aluminum)	Up to 6 mm (0.236 in)

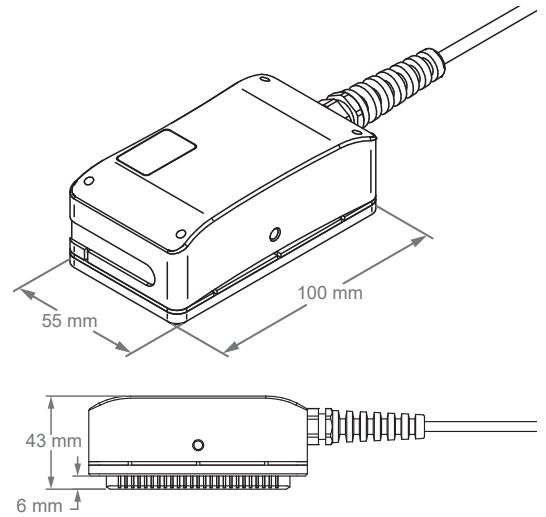

ECA-SFC-058-250-032-N03S

Designed to detect short, surface-breaking cracks and other surface defects in ferromagnetic materials with a high accuracy, the probe can be used on curved surfaces with an outside diameter of 0.41 m (16 in) or more.

Body	Semi-flexible
Casing	Medium
Topology	Long, single driver
Cable	3 m (9.8 ft)
Coverage	58 mm (2.28 in)
Central frequency	250 kHz
Frequency range	50–525 kHz
Coils (diameter × number)	3.5 mm × 32 (0.14 in × 32)
Channels	59
Minimum channel requirement	64
Minimum detectable crack length	1 mm (0.039 in)

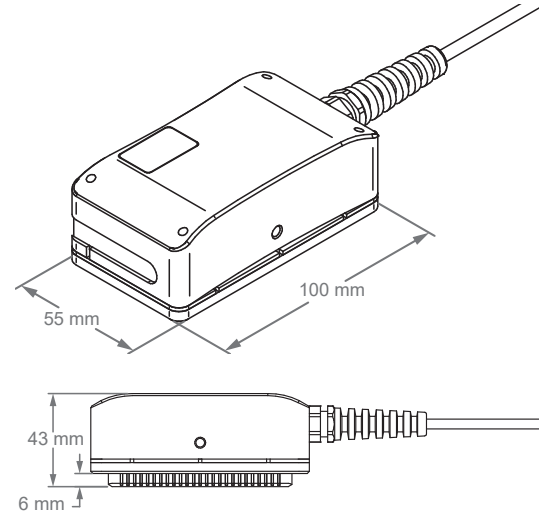

ECA-SFD-056-250-032-N03S

Designed to detect short, surface-breaking cracks and other surface defects in non-ferromagnetic materials with a high accuracy, the probe can be used on curved surfaces with an outside diameter of 0.41 m (16 in) or more.

Body	Semi-flexible
Casing	Medium
Topology	Short, double driver
Cable	3 m (9.8 ft)
Coverage	56 mm (2.21 in)
Central frequency	250 kHz
Frequency range	50–525 kHz
Coils (diameter × number)	3.5 mm × 32 (0.14 in × 32)
Channels	60
Minimum channel requirement	64
Minimum detectable crack length	1 mm (0.039 in)

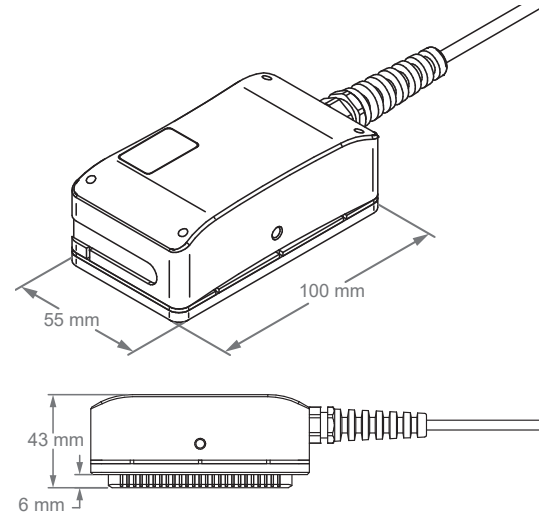

ECA-SFC-071-500-064-N03S

Super-high-resolution probe designed to detect very short, surface-breaking cracks in ferromagnetic materials. Note that you need 128 or 256 channels to use this probe. Consider ECA-SFC-035-500-032-N03S (page 21) as an alternative if you only have 64 available channels. The probe can be used on curved surfaces with an outside diameter of 0.41 m (16 in) or more.

Body	Semi-flexible
Casing	Medium
Topology	Long, single driver
Cable	3 m (9.8 ft)
Coverage	71 mm (2.80 in)
Central frequency	500 kHz
Frequency range	100–800 kHz
Coils (diameter × number)	2 mm × 64 (0.08 in × 64)
Channels	123
Minimum channel requirement	128
Minimum detectable crack length	0.5 mm (0.020 in)

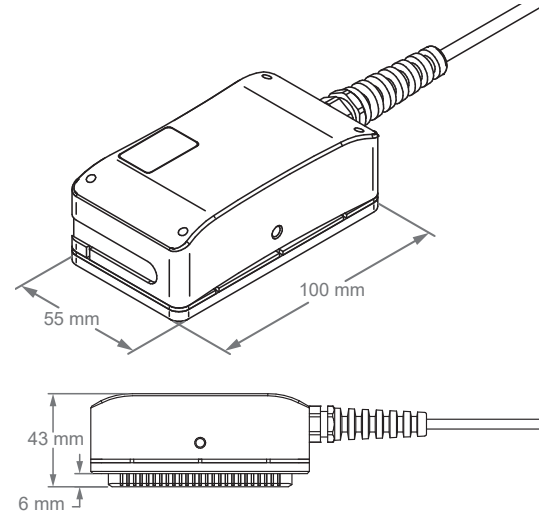

ECA-SFD-070-500-064-N03S

Super-high-resolution probe designed to detect very short, surface-breaking cracks in non-ferromagnetic materials. Note that you need 128 or 256 channels to use this probe. Consider ECA-SFD-034-500-032-N03S (page 21) as an alternative if you only have 64 available channels. The probe can be used on curved surfaces with an outside diameter of 0.41 m (16 in) or more.

Body	Semi-flexible
Casing	Medium
Topology	Short, double driver
Cable	3 m (9.8 ft)
Coverage	70 mm (2.76 in)
Central frequency	500 kHz
Frequency range	100–800 kHz
Coils (diameter × number)	2 mm × 64 (0.08 in × 64)
Channels	124
Minimum requirement	128
Minimum detectable crack length	0.5 mm (0.020 in)

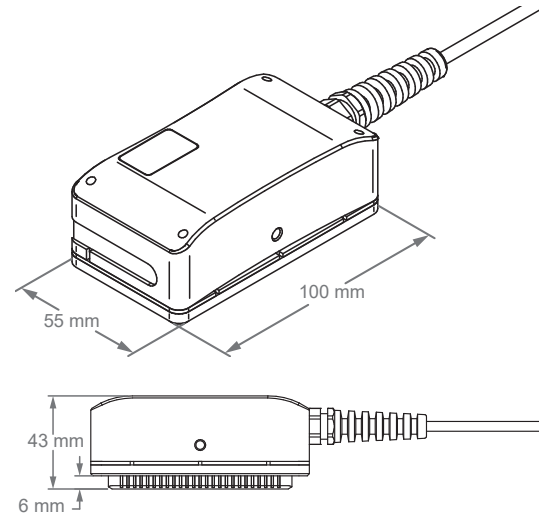

ECA-SFC-035-500-032-N03S

Super-high-resolution probe designed to detect very short, surface-breaking cracks in ferromagnetic materials. The probe offers approximately half the coverage of ECA-SFC-058-250-032-N03S (page 19), but only requires 64 channels. It can be used on curved surfaces with an outside diameter of 0.2 m (8 in) or more.

Body	Semi-flexible
Casing	Small
Topology	Long, single driver
Cable	3 m (9.8 ft)
Coverage	26 mm (1.02 in)
Central frequency	250 kHz
Frequency range	50–525 kHz
Coils (diameter × number)	3.5 mm × 16 (0.14 in × 16)
Channels	26
Minimum channel requirement	32
Penetration (stainless steel/aluminum)	Up to 3 mm (0.118 in)
Minimum detectable crack length	1 mm (0.039 in)

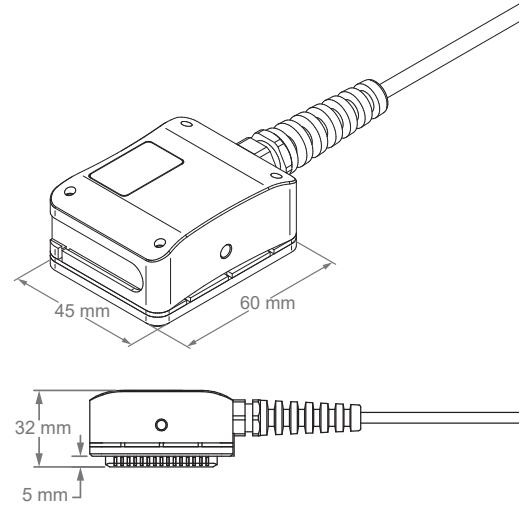

ECA-SFD-034-500-032-N03S

Super-high-resolution probe designed to detect very short, surface-breaking cracks, in non-ferromagnetic materials. The probe offers approximately half the coverage of the ECA-SFD-056-250-032-N03S (page 19), but only requires 64 channels. It can be used on curved surfaces with an outside diameter of 0.2 m (8 in) or more.

Body	Semi-flexible
Casing	Small
Topology	Short, double driver
Cable	3 m (9.8 ft)
Coverage	34 mm (1.34 in)
Central frequency	500 kHz
Frequency range	100–800 kHz
Coils (diameter × number)	2 mm × 32 (0.08 in × 32)
Channels	60
Minimum channel requirement	64
Minimum detectable crack length	0.5 mm (0.020 in)

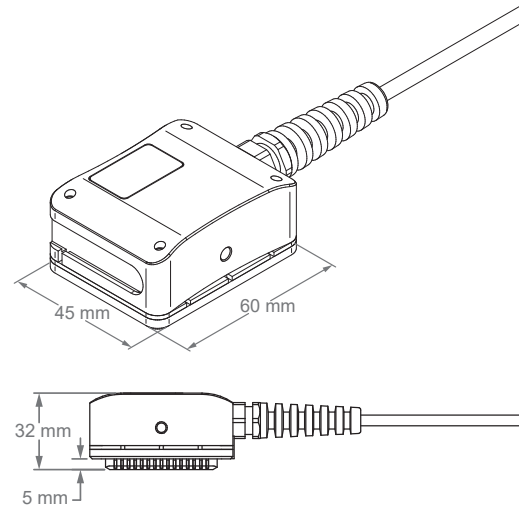

WELDS AND SMOOTH SURFACES — PADDED PROBES

Designed to detect welding defects in non-ferromagnetic materials, their padded membrane is extremely resistant to the harsh friction encountered in such applications, reducing weld preparation requirements to a minimum.

ECA-PDC-058-250-032-N03S

Designed to detect short, surface-breaking cracks and other surface defects in ferromagnetic materials, the probe's unique design enables it to adapt to weld crowns 5 mm (0.2 in) or less.

Body	Padded
Casing	Medium
Topology	Long, single driver
Cable	3 m (9.8 ft)
Coverage	58 mm (2.28 in)
Central frequency	250 kHz
Frequency range	50–525 kHz
Coils (diameter × number)	3.5 mm × 32 (0.14 in × 32)
Channels	59
Minimum channel requirement	64
Minimum detectable crack length	1 mm (0.039 in)

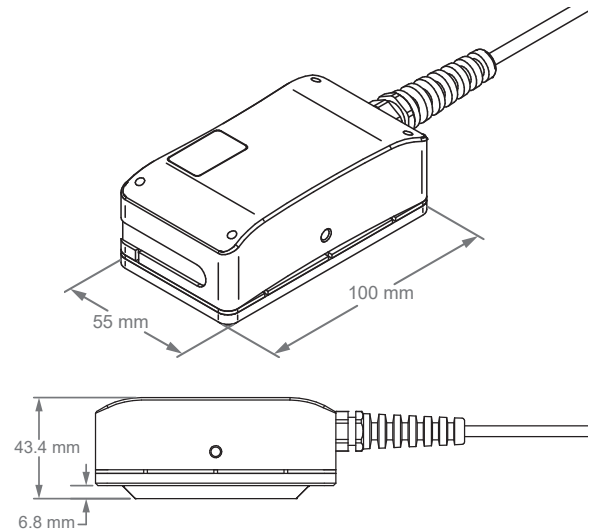

ECA-PDD-056-250-032-N03S

Designed to detect short, surface-breaking cracks and other surface defects in non-ferromagnetic materials, the probe's unique design enables it to adapt to weld crowns 5 mm (0.2 in) or less.

Body	Padded
Casing	Medium
Topology	Short, double driver
Cable	3 m (9.8 ft)
Coverage	56 mm (2.21 in)
Central frequency	250 kHz
Frequency range	50–525 kHz
Coils (diameter × number)	3.5 mm × 32 (0.14 in × 32)
Channels	60
Minimum channel requirement	64
Minimum detectable crack length	1 mm (0.039 in)

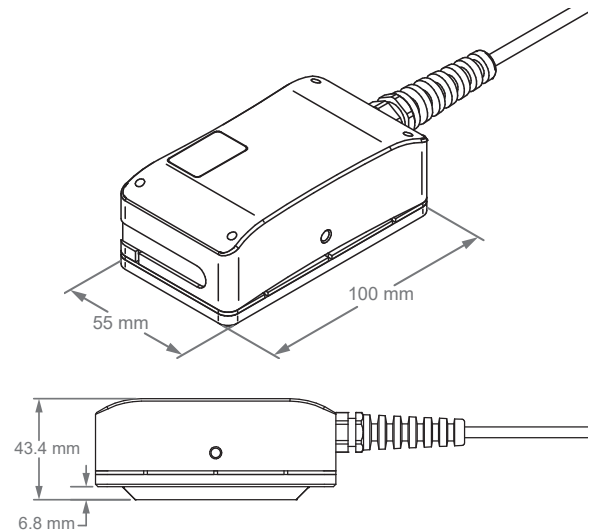

ECA-PDC-055-500-050-N03S

Super-high-resolution probe designed to detect very short, surface-breaking cracks in ferromagnetic materials. Note that you need 128, or 256 channels to use this probe. Consider ECA-PDC-035-500-032-N03S (page 24) as an alternative if you only have 64 available channels. The probe can adapt to weld crowns 5 mm (0.2 in) or less.

Body	Padded
Casing	Medium
Topology	Long, single driver
Cable	3 m (9.8 ft)
Coverage	55 mm (2.17 in)
Central frequency	500 kHz
Frequency range	100–800 kHz
Coils (diameter × number)	2 mm × 50 (0.08 in × 50)
Channels	95
Minimum channel requirement	128
Minimum detectable crack length	0.5 mm (0.020 in)

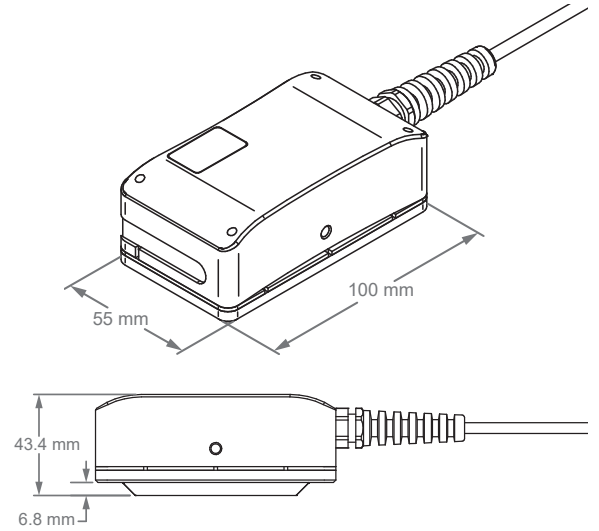

ECA-PDD-054-500-050-N03S

Super-high-resolution probe designed to detect very short, surface-breaking cracks in non-ferromagnetic materials. Note that you need 128, or 256 channels to use this probe. Consider ECA-PDD-034-500-032-N03S (page 24) as an alternative if you only have 64 available channels. The probe can adapt to weld crowns 5 mm (0.2 in) or less.

Body	Padded
Casing	Medium
Topology	Short, double driver
Cable	3 m (9.8 ft)
Coverage	54 mm (2.13 in)
Central frequency	500 kHz
Frequency range	100–800 kHz
Coils (diameter × number)	2 mm × 50 (0.08 in × 50)
Channels	96
Minimum channel requirement	128
Minimum detectable crack length	0.5 mm (0.020 in)

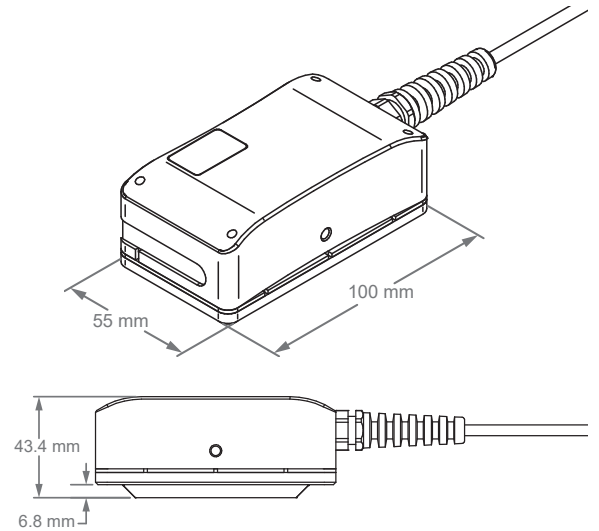

ECA-PDC-035-500-032-N03S

Super-high-resolution probe designed to detect very short, surface-breaking cracks and other surface defects in ferromagnetic materials. Its unique design enables it to adapt to weld crowns 5 mm (0.2 in) or less.

Body	Padded
Casing	Small
Topology	Long, single driver
Cable	3 m (9.8 ft)
Coverage	34 mm (1.34 in)
Central frequency	500 kHz
Frequency range	100–800 kHz
Coils (diameter × number)	2 mm × 32 (0.08 in × 32)
Channels	59
Minimum channel requirement	64
Minimum detectable crack length	0.5 mm (0.020 in)

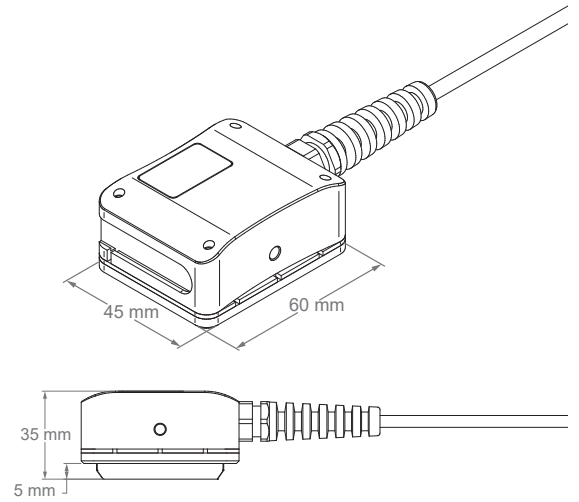

ECA-PDD-034-500-032-N03S

Super-high-resolution probe designed to detect very short, surface-breaking cracks and other surface defects in welds featuring weld crowns 5 mm (0.2 in) or less.

Body	Padded
Casing	Small
Topology	Short, double driver
Cable	3 m (9.8 ft)
Coverage	34 mm (1.34 in)
Central frequency	500 kHz
Frequency range	100–800 kHz
Coils (diameter × number)	2 mm × 32 (0.08 in × 32)
Channels	60
Minimum channel requirement	64
Minimum detectable crack length	0.5 mm (0.020 in)

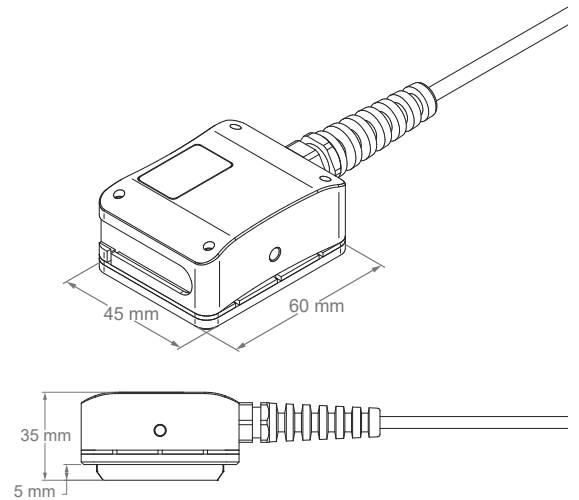

TURBINE APPLICATIONS

Gas turbines are critical assets in the power generation industry. They are large and complex, and shutting them down is often quite costly. Turbine blades, generator slots, rotor bores, bore holes, and dovetails must all be inspected regularly, quickly, and efficiently and each have very specific mechanical designs. They also tend to have unique geometries, depending on the manufacturer, that make it hard to inspect with conventional methods. These applications involve developing custom probes to fulfill each highly specific set of requirements. Over the years, Eddyfi Technologies gained a wealth of concrete experience developing ECA probes for these applications. By coming to us with your turbine application requirements, you're not starting from scratch. Rather, you have a great head start.

TURBINE BLADES

Several blades are equipped with cooling holes and gas paths, which are the source of several types of problems, such as subsurface defects and corrosion. Turbine blades also usually have very specific profiles and are sometimes coated. This presents a number of challenges for which we developed flexible ECA probes, trailing-edge probes, and many more.

GENERATOR SLOTS

In power generators, current flows through enormous stator bars running in wedged slots along the axis. Once generators have been operating for a long time, electromagnetic forces may cause the stator bars to vibrate because of loose slot wedges. This can generate fretting and cracking, so it is necessary to inspect slot wedges regularly. They require profiled ECA probes, which we designed for several customers.

ROTOR BORES



Many steam turbine rotors are bored to allow several shafts to be built into one another, making multiple rotation speeds possible. These bores need to be inspected for cracking, which can be difficult and time-consuming because of the length and diameter of the rotors. Eddyfi Technologies developed a system used by many in the industry to inspect bores with a combination of ECA and UT.

BORE HOLES

Rotor bores are also engineered with holes, where surface-breaking cracks can develop, creating the need to be detected. Eddyfi Technologies developed several probes to do this job.

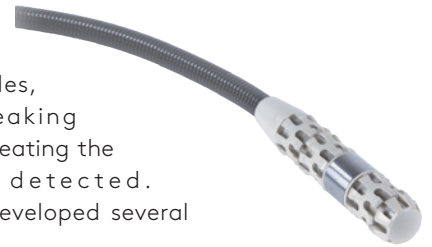

DOVETAILS

Turbine blades are generally attached to rotors through an ingenious system of male and female “dovetails” that must be inspected for defects to ensure safety and maximize the life of equipment. Dovetail inspection demands probes that are shaped to specific dovetail profiles; designed to specifically target “hot spots” or entire dovetail profiles; capable of fast single-pass scans of regions of interest; and easy to handle—all things that Eddyfi Technologies excels at designing.



CUSTOM ECA PROBES

At Eddyfi Technologies, we make the impossible possible. We have the expertise, the engineers, and the manufacturing capabilities to take almost any set of custom surface-inspection requirements—from dimensions, coil row number, to topologies—and turn them into practical solutions. We have had the opportunity to demonstrate this by developing:

- Static probes
- Clamping probes
- Encircling probes
- Spring-loaded probes
- Custom-geometry probes
- Gel-filled probes
- Individually spring-loaded elements
- Expandable probes
- Partial saturation probes

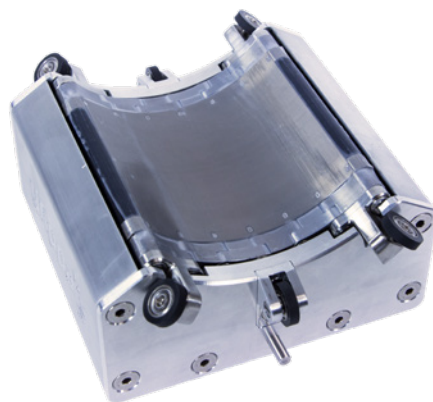

CALIBRATION STANDARDS

These reference plates are used to calibrate your probe for given applications.

APPLICATION	MATERIAL	THICKNESS	INDICATIONS	PART NUMBER
Corrosion	Grade 6061 aluminum	6.35 mm (0.250 in)	13 × FBH, Ø1.6–12.7 mm (0.063–0.500 in)	REFPL-A6061-0635-STDCOR01
Welds	Grade 316 stainless steel	6.35 mm (0.250 in)	9 × EDM notch 3 × FBH, Ø1.5 mm (0.059 in)	REFPL-SS316-0635-STDWLD01
Surface-breaking and subsurface defects	Grade 6061 aluminum	3.18 mm (0.125 in)	4 × EDM notch 6 × FBH, Ø3 mm (0.118 in)	REFPL-A6061-0318-STDCAL01
	Grade 316 stainless steel	3.18 mm (0.125 in)	4 × EDM notch 6 × FBH, Ø3 mm (0.118 in)	REFPL-SS316-0318-STDCAL01
	Grade 1018 carbon steel	3.18 mm (0.125 in)	4 × EDM notch 3 × FBH, Ø3 mm (0.118 in)	REFPL-C1018-0318-STDCAL02
	Grade 6061 aluminum	3.18 mm (0.125 in)	9 × EDM notch 1 × FBH, Ø3 mm (0.118 in) 1 × FBH, Ø1.5 mm (0.059 in) 1 × FBH, Ø0.75 mm (0.030 in)	REFPL-A6061-0318-STDCAL03
	Grade 316 stainless steel	3.18 mm (0.125 in)	9 × EDM notch 1 × FBH, Ø3 mm (0.118 in) 1 × FBH, Ø1.5 mm (0.059 in) 1 × FBH, Ø0.75 mm (0.030 in)	REFPL-SS316-0318-STDCAL03
	Grade 1018 carbon steel	3.18 mm (0.125 in)	9 × EDM notch 1 × FBH, Ø3 mm (0.118 in) 1 × FBH, Ø1.5 mm (0.059 in) 1 × FBH, Ø0.75 mm (0.030 in)	REFPL-C1018-0318-STDCAL03

ENCODER

ENC-STD-2-18P-N03S OR ENC-STD-2-12P-N03S

High-precision, high-resolution (25.46 counts/mm) encoder for standard surface probes, regardless of their size and type. Rugged aluminum casing, waterproof design, and easy to clean with a replaceable wheel. Equipped with an 18-pin connector compatible with Ectane or a 12-pin connector compatible with Reddy, and a 3 m (9.8 ft) cable. The click-on design of the encoder also makes it extremely simple to install without any tools.

- Rugged aluminum casing
- Waterproof
- Easy to clean
- User-replaceable wheel



The information in this document is accurate as of its publication. Actual products may differ from those presented herein.
© 2019 Eddyfi NDT, Inc. Eddyfi, Ectane, I-Flex, Magnifi, Reddy, Sharck, SmartMUX, TECA, T-Flex, and their associated logos are trademarks or registered trademarks of Eddyfi NDT, Inc. in the United States and/or other countries.
Eddyfi Technologies reserves the right to change product offerings and specifications without notice.

www.eddyfi.com

info@eddyfi.com

